

KERN & SOHN –
The wide range of product champion
that is situated in the Swabian Alb



Printed in Germany by KERN & SOHN GmbH · z4berhp20231

Discover the vast world of scales and
measuring technology from KERN online:
kern-sohn.com



Follow us also on our social media
channels



2023

BALANCES & TEST SERVICE for laboratory, industry and food industry

EN

EN

PROFESSIONAL MEASURING



BALANCES & TEST SERVICE

for laboratory, industry and food industry



How do I quickly find the product I am looking for?

The tried and tested quick search system – “Quick-Finder” ahead of each product group allows you to base the search for a certain target group on weighing data you need such as readout, weighing capacity and main features for each model.

And it's as simple as that – find the product you want in 2 steps:

1. Go to the product group index on page 3
2. Pick the appropriate product group and find the product you want using the Quick-Finder.

... or use the model name and find the product quickly and efficiently using the A-Z model list:



KERN Models A–Z

440	28
572	30
A	
ABS-N/ABJ-NM	42/43
ACS/ACJ	42/43
ABP	46-47
ABP-A	48
ABT-NM	44
ADB/ADJ	39
ALS-A/ALJ-A	40/41
B	
BFB	116/117
BFN	118
BIC	113
BID	114/115
C	
CH	159
CCA	88/89
CCS	90/91
CDS	87
CEHX	130
CFS	84
CKE	85
CIB	81
CM	12
CB · CJ · CO · CP · CR · CT	147-153
CPB	83
CXB/CXB-NM	82
D	
DAB	50
DBS	51
DE-D	100/101
DLB	52
DS	107
E	
ECB-NECE-N	55
EFS	15
EG-NEW-N	33
EHA	19
EMB	16
EMB-V	17
EMS	18
EOB	98
EOS	99
EOC	102/103
EOE	97
EWJ	29
F	
FCB	57
FCE-N	56
FCF	64
FES/FEJ	37
FFN	69
FGE	63
FKB	58/59
FOB · FOB-NL	67
FOB-LM	65
FOB-S · FOB-NS	66
FXN · FXN-M	70
G	
GAB-N	60
H	
HCB	161
HCN	162
HCD	163
HDB-N · HDB-XL	160
HFA	164
HFC	165
HFD	166/167
HFM	168
HGA	158
I	
IFB	106
IFS	86
IOC	104/105
IXS	109/110
K	
KDP	131
KFA-V20	144
KFB-TM	140
KFD-V20	143
KFD-V40	145
KFN-TM	141
KFP-V20 IP65	142
KFP-V20 IP67	143
KFP-V30	144
KFP-V40	145
KFS-TM	140
KFU-V20	144
KFU-V30	144
KGP	128
KIB-TM	141
KIP-V20M	143
KXP-V20 IP65	142
N	
NIB	124
NFB	125
NFN	126
P	
PBJ/PBS	35
PCB	26/27
PCD	24
PEJ/PES	36
PFB	25
PLJ/PLS	31
PNJ/PNS	32
PWS	34
R	
RFE	77
RIB	75
RPB	76
S	
SFB/SFB-H	71
SFE	108
SXS	72/73
T	
TGC	13
TGD	13
U	
UFA	119
UFB	122
UFN	123
UIB	120
UID	121
V	
VHB	155
W	
WTB	68
Y	
YKV	129
YRO-01/-02/-03	181



KERN Pictograms

 Internal adjusting: Quick setting up of the balance's accuracy with internal adjusting weight (motordriven)	 Network interface: For connecting the scale to an Ethernet network	 Suspended weighing: Load support with hook on the underside of the balance
 Adjusting program CAL: For quick setting up of the balance's accuracy. External adjusting weight required	 KERN Communication Protocol (KCP): It is a standardized interface command set for KERN balances and other instruments, which allows retrieving and controlling all relevant parameters and functions of the device. KERN devices featuring KCP are thus easily integrated with computers, industrial controllers and other digital systems	 Battery operation: Ready for battery operation. The battery type is specified for each device
 Easy Touch: Suitable for the connection, data transmission and control through PC or tablet.	 GLP/ISO log: The balance displays weight, date and time, independent of a printer connection	 Rechargeable battery pack: Rechargeable set
 Memory: Balance memory capacity, e.g. for article data, weighing data, tare weights, PLU etc.	 GLP/ISO log: The balance displays weight, date and time, independent of a printer connection	 Universal plug-in power supply: with universal input and optional input socket adapters for A) EU, CH, GB B) EU, CH, GB, USA C) EU, CH, GB, USA, AUS
 Alibi memory: Secure, electronic archiving of weighing results, complying with the 2014/31/EU standard.	 GLP/ISO log: With weight, date and time. Only with KERN printers.	 Plug-in power supply: 230V/50Hz in standard version for EU, CH. On request GB, USA or AUS version available
 KERN Universal Port (KUP): allows the connection of external KUP interface adapters, e.g. RS-232, RS-485, SB, Bluetooth, WLAN, Analogue, Ethernet etc. for the exchange of data and control commands, without installation effort	 Piece counting: Reference quantities selectable. Display can be switched from piece to weight	 Integrated power supply unit: Integrated in balance. 230V/50Hz standard EU. More standards e.g. GB, USA or AUS on request
 Data interface RS-232: To connect the balance to a printer, PC or network	 Recipe level A: The weights of the recipe ingredients can be added together and the total weight of the recipe can be printed out	 Weighing principle: Strain gauges Electrical resistor on an elastic deforming body
 RS-485 data interface: To connect the balance to a printer, PC or other peripherals. Suitable for data transfer over large distances. Network in bus topology is possible	 Recipe level B: Internal memory for complete recipes with name and target value of the recipe ingredients. User guidance through display	 Weighing principle: Tuning fork A resonating body is electromagnetically excited, causing it to oscillate
 USB data interface: To connect the balance to a printer, PC or other peripherals	 Totalising level A: The weights of similar items can be added together and the total can be printed out	 Weighing principle: Electromagnetic force compensation Coil inside a permanent magnet. For the most accurate weighings
 Bluetooth® data interface: To transfer data from the balance to a printer, PC or other peripherals	 Percentage determination: Determining the deviation in % from the target value (100 %)	 Weighing principle: Single cell technology: Advanced version of the force compensation principle with the highest level of precision
 WiFi data interface: To transfer data from the balance to a printer, PC or other peripherals	 Weighing units: Can be switched to e.g. non-metric units. See balance model. Please refer to KERN's website for more details	 Verification possible: The time required for verification is specified in the pictogram
 Control outputs (optocoupler, digital I/O): To connect relays, signal lamps, valves, etc.	 Weighing with tolerance range: (Checkweighing) Upper and lower limiting can be programmed individually, e.g. for sorting and dosing. The process is supported by an audible or visual signal, see the relevant model	 DAKkS calibration possible (DKD): The time required for DAKkS calibration is shown in days in the pictogram
 Analogue interface: to connect a suitable peripheral device for analogue processing of the measurements	 Hold function: (Animal weighing program) When the weighing conditions are unstable, a stable weight is calculated as an average value	 Factory calibration (ISO): The time required for Factory calibration is shown in days in the pictogram
 Interface for second balance: For direct connection of a second balance	 Protection against dust and water splashes IPxx: The type of protection is shown in the pictogram.	 Package shipment: The time required for internal shipping preparations is shown in days in the pictogram
	 Pallet shipment: The time required for internal shipping preparations is shown in days in the pictogram	

KERN – Measuring technology and testing services from a single source



Balances & Test service catalogue

Provides a complete overview of the KERN line of balances, test weights, and services such as verification, calibration, etc.

Medical scales catalogue

Complete line of medical scales, from infant scales to patient scales, chair scales and adiposity scales, as well as hand grip dynamometers, chemist's balances and veterinary scales.

Microscopes & Refractometers catalogue

Extensive range in the area of optical instruments, such as, biological microscopes, stereo microscopes, metallurgical microscopes as well as analogue and digital refractometers.

SAUTER measuring equipment catalogue

Test instruments for industry and commerce, such as force, coating thickness, material thickness and calibration service.

Test service brochure

Detailed information on topics pertaining to the calibration and verification of balances, test weights, and force measuring devices.

Your advantages

fast

- 24 hours delivery service for products in stock – ordered today, on its way tomorrow
- Sales & service hotline available from 8:00 am to 6:00 pm

reliable

- Up to 3 years warranty
- Precision in weighing technology for more than 175 years

competent

- DAKkS accreditation
DIN EN ISO/IEC 17025
- Certified QM system
DIN EN ISO 9001
- Authorisation for initial verification by the manufacturer 2014/31/EU
- Medical certifications
DIN EN ISO 13485 and 93/42/ EWG

versatile

- One-stop shopping: from pocket balances through to 12 t crane balance – everything from one supplier
- Find the product you want at lightning speed with the "Balance Quick-Finder" at www.kern-sohn.com

Keyword index

A	
Adiposity scales	see website
Accessories	169–181
Alibi memory	223
Aluminium sample plate	49-52
Analogue refractometer	see website
Analytical balances	38-48
Animal scales	57-58, 64-65, 72-73, 97-110, 113-126, 159-162

B	
Baby scales	see website
Bench scales	53–60
Bluetooth/RS-232 Adapter	177
Body fat scales	see website

C	
Calibration Service	210-222
Carat balances	13, 17, 26-37, 39-44, 46-48
Catalogues, Brochures, Flyer	2, 226
Chair scales	see website
Chair weighers	see website
Coating thickness gauges	see website
Column	179
Control of checking equipment	210-222, 225
Counting scales	78–92
Counting systems	88–91
Crane scales	163–168

D	
DakKS/ DKD	210-222
Density determination	13–14, 22–23, 25, 27–28, 30-32, 36–41, 98
Display devices	130, 140-141
Drive-through scale	124-126
Drying balance	49–52

E	
Earth's gravitational force	224
EasyTouch App	132-135
Equipment qualification	211
Ethernet/RS-232 Adapter	176
Explosion hazard	226

F	
Factory calibration	211, 221-222
Floor scales	101-126
Foot switch	26, 73, 110
Force gauges	see website

G	
Grain balances	see website
Glossary	223–225

H	
Handrail scales	see website
Hanging scales	156–168
Hardness tester	see website
Height rods	see website
Hydrostatic balances	16-17, 24-25, 27, 30-31, 33, 35, 40-44, 46-48, 107

I	
Industrial scales	53–155
Information	223-226
Interface cable	173
Ioniser	39-44, 180
IP 65...68 protected scales	65-73, 108, 123, 126
ISO calibration	211, 221-222

J	
Junction box	153

K	
Kitchen scales	63

L	
Laboratory balances	14-52
Length measuring devices	see website
Lexicon	223–225
Load cells	146–152
Luggage scale	158

M	
Material thickness gauge	see website
Load cells	146–152
Mechanical balances (spring balances)	see website
Medical scales	see website
Microscopes, biological	see website
Microscopes, metallurgical	see website
Microscopes, polarisation	see website
Microscopes, stereo	see website
Minimum sample weight	215
Mobile pallet weigher	154–155
Moisture analysers	49–52

P	
Pallet scales	120-123
Personal floor scales	see website
Personal scales	see website
Pictogram overview	2
Platform scales	93–110
Platforms	128, 131, 142-145
Plummet, density determination	179
Pocket balances	11–13
Power supply adapter set	178
Pre-packaging legislation (FPVO)	224
Precious stones plate	32, 39
Precision balances	20–37
PREMIUM+ WEIGHTS	183
Price computing scales	74–77
Printers	170–172
Protective dust cover	179

R	
Recalibration	214, 218
Refractometers, digital	see website
Retail balances	74–77
Roller conveyor	181
Round fiberglass filter	50-52
RS-232/Bluetooth-Adapter	177
RS-232/Ethernet-Adapter	176
RS-232/USB-Adapter	178
RS-232/ WiFi-Adapter	176

S	
Safety Set	184
Semi-micro balances	40/41, 44, 46-48
Shop balances	74–77
Signal lamp	178
Software	132-135, 174-175
Spring balances	see website
Stainless steel scales	65-67, 69-73, 108-110, 118, 123, 126

T	
Tare pan	179
Temperature calibration set	49-52
Tensile force measurement device	164–165
Terminals	130, 140-141
Test service	210-222
Test stands	see website
Test weights	189-209
Touchscreen scales	132-135
Tweezers	205

U	
Underfloor weighing, accessories	16-17, 24-25, 30-32, 36, 40-44, 46-48, 85, 87, 107

V	
Verification	219, 223
Verification plug	104-105, 114-115, 121

W	
Weighing beams	119
Weighing bridges	142-145
Weighing Systems Industry 4.0	128-131
Weighing table	180
Weighing transmitter, digital	129
Wheelchair platform scales	see website
WiFi/RS-232 Adapter	176

ambifood

Product group index 2023

01 Pocket balances 11–13 	02 School balances 14–19 	03 Precision balances 20–37 
04 Analytical balances 38–48 	05 Moisture analysers 49–52 	06 Bench scales 53–60 
07 Food (kitchen/stainless steel/IP65...68 protection) 61–73 	08 Price computing scales 74–77 	09 Counting scales/ Counting systems 78–92 
10 Parcel scales/ Platform scales 93–110 	11 Floorscales/Pallet scales /Drive-through scales 111–126 	12 Weighing Systems Industry 4.0/EasyTouch 127–135 
13 Display devices/Platforms /Weighing bridges/ Load cells 136–153 	14 Pallet truck scales 154–155 	15 Hanging scales/ Crane scales 156–168 
16 Accessories 169–181 	17 Test weights 182–209 	18 DAkkS Calibration Service /Verification service 210–222 



Rua Dominguez Alvarez, 44,
escritórios 4.16, Edifício Porto
Magnum, 4150-801 Porto

Ambifood.com

WHEN DESIGN MEETS PERFORMANCE

May we introduce...? The new models from the KERNIoTLine are celebrating their debut.

Together we can enjoy the shared, advanced-looking KERNdesign, the consistent and simplified handling, the high connectivity level, and a persuasive performance that operates across all devices.



Dive into our new KERNbrand universe.



Design

- + Trend-setting, high-quality KERN design
- + Recognisability through uniform product range
- + Reliable brand values are reflected visually and functionally in the product



Performance

- + Cross-device functionality and protocols
- + Consistently reliable performance
- + The latest technologies
- + Cross-device functionality and protocols



Philosophy

- + Sustainable due to high energy efficiency
- + Standardisation of design components across all units
- + Controlled value chain
- + Tested and monitored technology for maximum user safety



Are you curious about the models in the KERN IoT range and what opportunities they offer?

Then take a look at pages 8/9, because thanks to new technologies such as KUP and KCP these models are perfectly equipped for the wide range of challenges of Industry 4.0



User Interface

- + Uniform, simplified user guidance
- + Problem-free commissioning, use and expansion
- + Cross-model software



Service

- + Fast and competent help from our IoT specialists
- + Even more efficient repair process
- + Accessories can be flexibly combined

Note: Our KERNIoT accessories can be easily combined with all our IoT models.

Find the right printer and other practical accessories on page 169 or in our online shop www.kern-sohn.com

ARE YOU READY?

With the KERNUniversal Port (KUP) and the KERN Communication Protocol (KCP) we ensure the perfect integration of your KERNbalance into production or process chains for a complete, simplified work process.

Our products will make sure you are prepared for the future of weighing in the Internet of Things. Get IoT ready – with the IoT models from KERN.

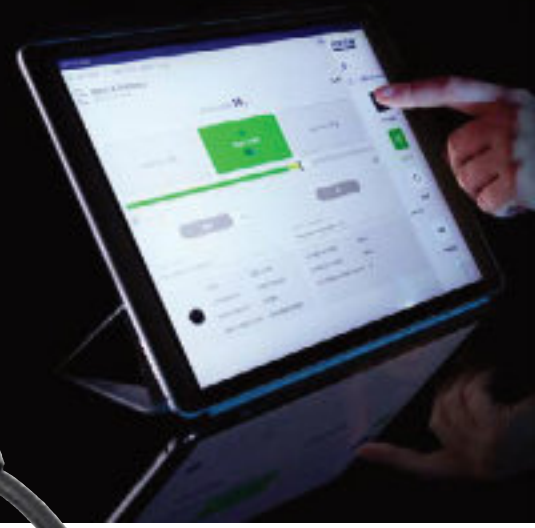

KERN Universal Port (KUP)

The integrated KERNUniversal Port (KUP) allows the connection of external KUP interface adapters such as RS-232, USB, Bluetooth, WiFi, Analogue, Ethernet etc.

The outstanding advantage here is that the KUPinterface adapters are simply plugged in, i.e. retrofitting interfaces is conveniently possible without opening the scale housing or complicated installation.

The interface adapters enable convenient transmission of weighing data to networks, PCs, smartphones, tablets, laptops, printers etc. In addition, control commands and data inputs can also be sent to the scale via the connected devices.

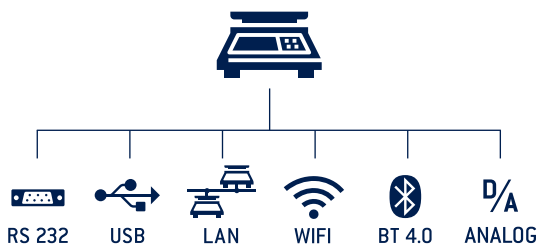

Tip: With the KERNKUP-13extension box, up to three KUPinterface adapters can be operated in parallel on the scale.

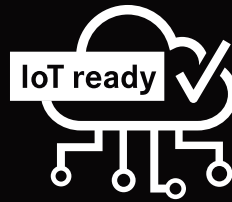

KERN Communication Protocol (KCP)

The KERNCommunication Protocol (KCP) permits searching and remote control of the balance through external control devices or computers using the KERNCommunication Protocol. KCP is a standardised interface command structure for KERN balances and other measuring instruments which allows you to recall and manage all relevant parameters and device functions. You can therefore simply connect KERN models with KCP to computers, industrial control systems and other digital systems.

In a large number of cases the KERN Communication Protocol is compatible with the MT-SICS protocol. KCP is available through all KUPs, and on the KERNKIB-TM display device through the interfaces available.

KCP – EXPORT („OUTBOUND“) – THE HIGHLIGHTS

- Stable, immediate weight
- Live transfer of weights
- Storing of gross weight, tare weight, net weight, stability, date, time etc., in the tamper-proof Alibi memory
- Output of the weighing result in percent
- Output of the weighing result in pieces (piece-counting function)
- Output of the weight at freely-definable timed intervals
- and much more

KCP – IMPORT („INBOUND“) – THE HIGHLIGHTS

- Recall of the central device data
- Setup or recall of an individual device ID number
- Setting or searching for a tare value (pre-tare value) externally
- Recall of stored weighing results from the alibi memory
- Carrying out external adjustment/linearization
- Setting the reference values in the balance externally and outputting the weighing result in percent or in pieces
- Setting a network address for the balance (IP) – also for WiFi
- and much more

NEW IN → 2023

Innovative technology, stunning performance, improved features – all in proven KERNquality. You can see all our new additions in 2023 here – come and be inspired.



The born stacker – happily comes back to school

→KERN EFS SCHOOL BALANCE

The uncomplicated companion for all school laboratories and other educational institutions. Easy handling, durable and robust, it can cope well with changing users. With its tremendous weighing range, it is a typical nerd and without a doubt at the top of its class. For details, see page 15



First Class products in an IP-protected stainless steel housing

→KERN PWS PRECISION BALANCE

Resistant to fine particles and water splashes, withstands high loading. Let its high performance for reliable, high precision measurements impress you.

For details, see page 34



Proven KERN models – now with a facelift!

Proven KERN models – now with a facelift! These KERN models feature plenty of improved technology (IoT, KUP) and a refreshed KERN look:

→KERN PCB PRECISION BALANCE
For details, see page 26/27

→KERN 572 PRECISION BALANCE
For details, see page 30

→KERN CKE COUNTING BALANCE
For details, see page 85

→KERN CDS COUNTING BALANCE
For details, see page 87

→KERN IOC PLATFORM SCALES
For details, see page 104/105

→KERN DS PLATFORM SCALES
For details, see page 107



High-capacity precision balances with password-protected user administration

→KERN FES/FEJ PRECISION BALANCE

With this robust allrounder you are particularly well-equipped for the pharmaceutical industry. Here you can easily allocate and manage different users.

For details, see page 37



Our Flagship – now with fully automatic doors

→KERN ABP-A ANALYTICAL BALANCE

Our KERN Showcase model now features a super practical innovation, making your daily laboratory life easier—singlehandedly. For details, see page 47/48



→IoT-ready models (with KUP) carry this icon



14

PALLET TRUCK SCALES

Weighing and transporting – just one operation

Speed up your warehouse and dispatch processes with the KERNpallet truck scales.

Get the exact weight of a load and at the same time, transport it to a specific location, all in one operation. This reduces commissioning times and avoids queues in front of fixed floor scales.

These mobile weighing solutions are space-saving and deliver reliable weighing results. Differences between given and actual weights can be determined quickly e.g. in the goods-in and out department. This uncovers inaccurate quantities, saves time and money and therefore ensures a very short amortisation period of the scales original cost.

KERNpallet truck scales are of robust industrial quality, with high-level protection against dust and water splashes, with high-contrast, easy-to-read displays as well as solid wheels and load rollers – all this helps to give you practical support in your work – day after day.

Of course, all KERNpallet truck scales can also be calibrated and delivered with a DAkkS calibration certificate (optional). This ensures the high level of accuracy of your pallet truck scale.

PREMIUM
★ ★ ★

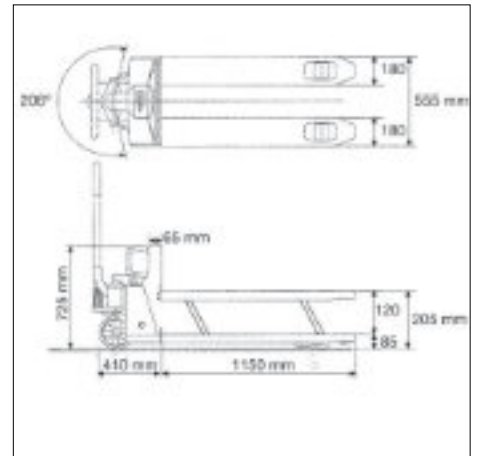

Pallet truck scale with complete protection against dust and water splashes IP65/67 and a memory for a container weight

Features

- PRE-TARE function for manual subtraction of a known container weight, useful for checking fill-levels
- 1 Display device: Plastic, protected against dust and water splashes IP65
- 2 Load fork: Protection against dust and water splashes IP67, temporary use in wet areas possible
- Pivot range 206°
- Castors: Solid rubber on aluminium rims
- 3 Load rollers: Tandem tyres to overcome thresholds and obstacles more easily
- Totalising of weights
- Ready for use: Batteries included, 4x1.5 V AA, operating time up to 80 h

Technical data

- Large LCD display, digit height 28 mm
- Permissible ambient temperature -10°C/40 °C

Accessories

- 4 Castors made of polyurethane (colour exemplary) on aluminium rims. Ideal for light-coloured flooring as they leave less visible abrasive marks. Suitable for the current models of the pallet truck scale range KERN VHB (when retrofitting, please give the serial number of the pallet truck scale available when ordering), scope of delivery: 1 item, KERNVHB-A02, € 140,-



! Shipment via freight forwarder. Please ask for dimensions, gross weight, shipping

STANDARD



OPTION



Model	Weighing capacity	Readability	Net weight	Price excl. of VAT ex works €	Option DAKKS KERN €	Option Certificate Certificate €
KERN VHB 2T1	[Max] kg 2000	[d] kg 1	approx. kg 110	1810,-	963-131	260,-

18

DAKKS CALIBRATION SERVICE/ VERIFICATION SERVICE

The DAkkS (German accreditation body)

The DAkkS is the national accreditation body of the Federal Republic of Germany. According to Regulation (EC) No. 765/2008 and the Accreditation Body Act (AkkStelleG), the DAkkS acts in the public interest as the sole service provider for accreditation in Germany.

In order to be able to fulfil its sovereign accreditation tasks, the DAkkS was entrusted by the Federal Government. As an entrusted body, the DAkkS is subject to federal supervision.

Only an accredited calibration laboratory can issue a DAkkS calibration certificate. This defines not only the measuring method as well as the measuring result, but also gives information on tracing the test medium to national standards and the relevant uncertainty of measurement.

-
- > **You are certified to ...**
ISO 9001, QS 9000, GLP, GMP, TS16949
 - > **You need ...**
to control your measuring equipment
 - > **Our solution ...**
DAkkS calibration certificate; (traceability, measuring uncertainty, internationally recognised)
-

KERN – Precision is our business

The KERN calibration laboratory for electronic balances and weights has been accredited by DKD since 1994 and today is one of the most modern and best-equipped DAkkS calibration laboratories for balances, test weights and force measurement in Europe.

Thanks to the high level of automation, we can carry out DAkkS calibration of balances, test weights and force-measuring devices 24 hours a day, 7 days a week.

Do you have any further requests or questions on this matter? We would be pleased to help you or visit us on the web at www.kern-lab.com

DAkkS calibration

Why? DAkkS calibration is always necessary when checking equipment (balance or test weight) is to be used in a QM process (e.g. to ISO 9000ff, GS 9000, TS 16949, VDA 6.1, FDA, GLP, GMP, GMP etc.)

What? Any checking equipment in proper condition can be DAkkS calibrated

How? Determination of accuracy throughout the world by a laboratory which is accredited to DIN EN ISO 17025. Traceability to internationally recognised standards. The DAkkS calibration certificate confirms both the measurement characteristics of the checking equipment and the general requirements for the control of checking equipment.

Where? Internationally recognised – this is monitored by ILAC (International Laboratory Accreditation Cooperation) and e.g. DAkkS (German calibration service) in Germany

When? The operator controls the use of checking equipment and periodic recalibration time intervals themselves

Range of services:

- DAkkS calibration of balances with a maximum load of up to 50.000 kg
- DAkkS calibration of weights in the range of 1 mg – 2.500 kg. Calibrations can be carried out in the following classes: E1, E2, F1, F2, M1, M2, M3
- DAkkS calibration of force gauges and force transducers
- Volume determination for weights of accuracy class E1
- Measuring of sensitivity (magnetic characteristics)
- Factory calibration in various sizes:
- Force (sensors and measuring devices), hardness (Shore, UCI, Leeb, etc.), thickness of coatings and walls, torque wrench testing devices, and much more
- Conformity assessments and recalibration of balances and weights at the KERN verification point, working closely with the verification authorities

And on top of all these services, we also offer additional services – see page 212/213.

Balance & weight in the quality management system

Do you already use all the modules of the KERNprecision package for maximum accuracy and reliability of your balance?

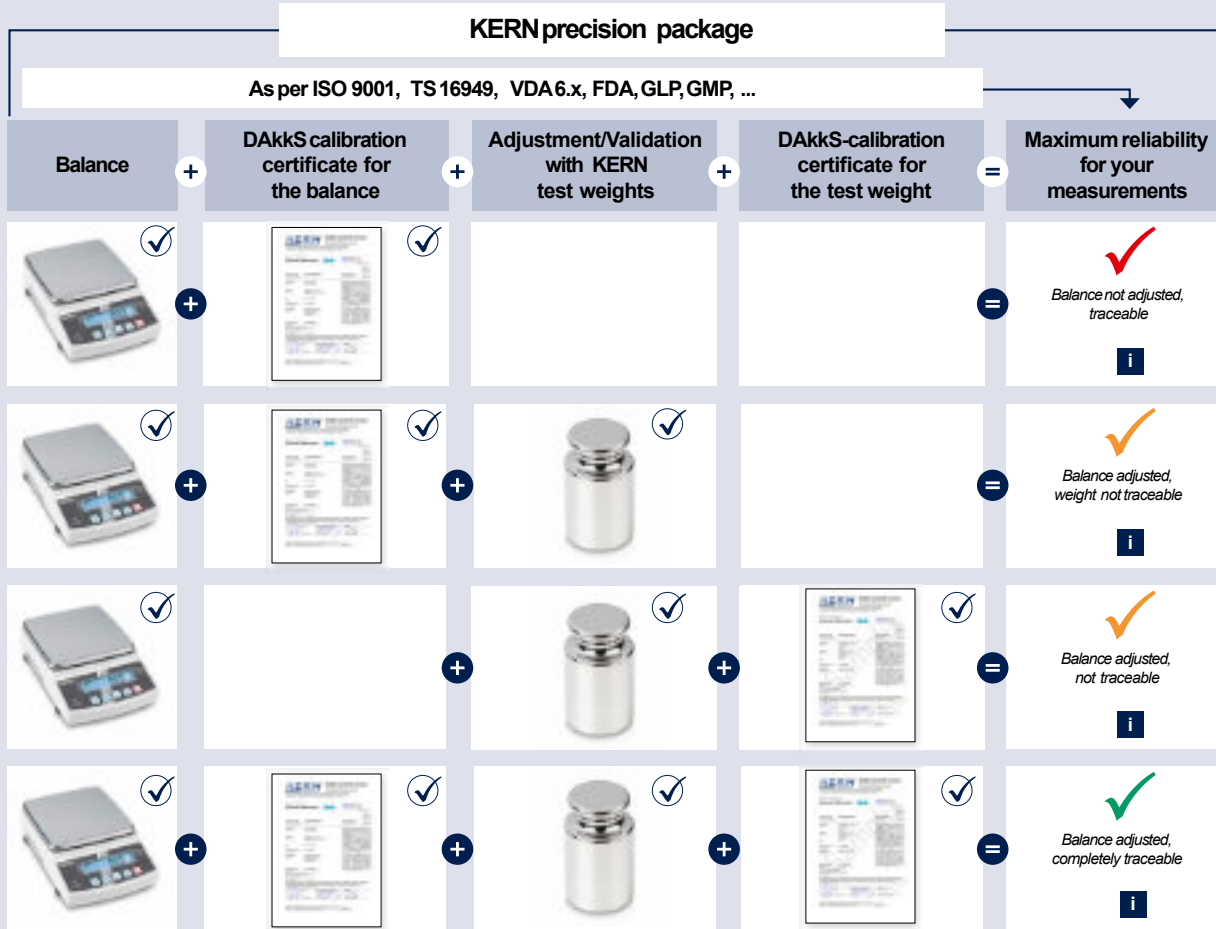

Information & ordering:
kern-sohn.com/qmb

The KERNcalibration laboratory (D-K-19408-01-00)

KERN has a highly-automated DAkkS laboratory with accreditation to DIN EN ISO/IEC 17025 in the field of balances, test weights and force measurement. By using the most modern calibration technology with high-end calibration robots in fully air-conditioned laboratories, the measurement uncertainty and process times are reduced to a minimum, and also the quality of the calibration is increased.

As an accredited and certified calibration service provider with decades of experience, KERN offers you an extensive range of services, which will leave no demand unfulfilled. The accreditation applies to the extent specified in the appendix to the certificate D-K-19408-01-00.

We offer the following services:

Waagen:

- ▶ DAkkS calibration up to 50 t
- ▶ Minimum sample weight (in use)
- ▶ Usage accuracy
- ▶ Adjustment at the location of installation
- ▶ Certificate of conformity
- ▶ Equipment qualification:
 - > Design qualification (DQ)
 - > Installation qualification (IQ)
 - > Function qualification (OQ)
 - > Performance qualification (PQ)
 - > Maintenance qualification (MQ)
- ▶ Verification

Weights:

- ▶ DAkkS calibration up to 2.5 t (OIML classes E1 – M3)
- ▶ Volume determination for OIML class E1
- ▶ Measuring of sensitivity (magnetic characteristics)
- ▶ Verification

Force measuring devices and force transducers:

- ▶ DAkkS calibration up to 5 kN

Factory calibration for:

- ▶ Force measuring devices and force transducers ≤ 250 kN
- ▶ Hardness
- ▶ Layer thickness
- ▶ Material thickness
- ▶ Temperature of moisture analysers

Our commitment to satisfy our customers never stops. Perhaps this is one of the reasons why our roots can perhaps be traced so far back in history. **Discover the KERN route to success: fast - competent - reliable - versatile!**

The order process

- 1 You will receive a **reminder** that your test equipment is due or you will generate online a quotation for new or existing test equipment
- 2 Submission or collection of your test equipment
- 3 Initial inspection of your goods, to check that they are suitable for calibration, and are complete, etc.
- 4 You will get a detailed order confirmation
- 5 Our experts will carry out initial calibration
- 6 Checked for conformity with required tolerances and if required, any necessary actions which arise from this are carried out
- 7 Before these actions are carried out, we will contact you (in so far as no individual processing has been agreed with you beforehand)
- 8 After your approval the necessary actions will be implemented and the calibration will be completed
- 9 After that your test equipment will be returned to you without delay, together with the appropriate calibration certificates
- 10 We will monitor your recalibration periods and will send you a reminder about your next calibration, free of charge

Our service



►Reminder service

The continuous cyclic recalibration of your checking equipment is an integral part of the reliable management of test equipment. You can rely on us to support you, and we will remind you in time, free of charge, when the next recalibration is due. In addition, you have the option of managing your test equipment online by yourself (cf. 1, 10).

►Quote generator

You will be impressed by our price-to-performance ratio. Request a non-binding quotation or create it yourself to suit your specifications at www.kern-lab.com (cf. 1)

►Collection service

We will be pleased to arrange a pick up by our forwarding agent the goods from your premises. You only need to tell us the weight and dimensions of your package and leave the rest to us (cf. 2)

►Repair and reconditioning of balances and weights

KERN will get your weights back up to standard, regardless of the manufacturer. Whether it is adjustment, marking, sand blasting or lacquering - the aim here is compliance and long-term stability. Any repairs of balances and instruments which may be necessary can be carried out quickly and easily (cf. 5, 6)

►Individual processing

In order to avoid delays with future orders, we would be pleased to incorporate your individual requirements for future processing of such calibration results. Even for smaller issues such as the printing of calibration certificates (stapling, punching, double-sided) we can work to your requirements (cf. 8).

►Express service and dispatch

If you need a particularly fast service, you can use your DAKK S express service. You will receive your test equipment after only 2 days (cf. 9).

www.kern-lab.com – the central portal for everything you need to know about the extensive KERN calibration services

On our website you will always find the latest news and useful information about testing and measuring devices, calibration, legal metrology and expansions to our range of services. You will also find numerous online services on the website.

Database supported management of test equipment

Information on your test equipment which has been calibrated by us is stored in our database. In this way it is possible to make trend calculations. You will therefore get an overview about the long-term stability and trend behaviour of your test equipment as well as the necessary recalibration period can easily be determined and specified.

Paperless documentation

So there is no administrative effort, we can handle all calibration documentation in a paperless process. From quotation, through to order confirmation, delivery note and invoice right up to calibration certificate, you will receive all documents by e-mail or you can retrieve them online. Would you prefer to receive your certificate or your invoice in paper form, for example? Of course this is not a problem either. We will send you everything you require by post.

Calibration certificate download

By using our download service you can easily download your calibration certificates as soon as the calibration work is complete and you will have access to them at any time in the future. Simply create your user account on www.kern-lab.com and you will never have to look for your certificates again.

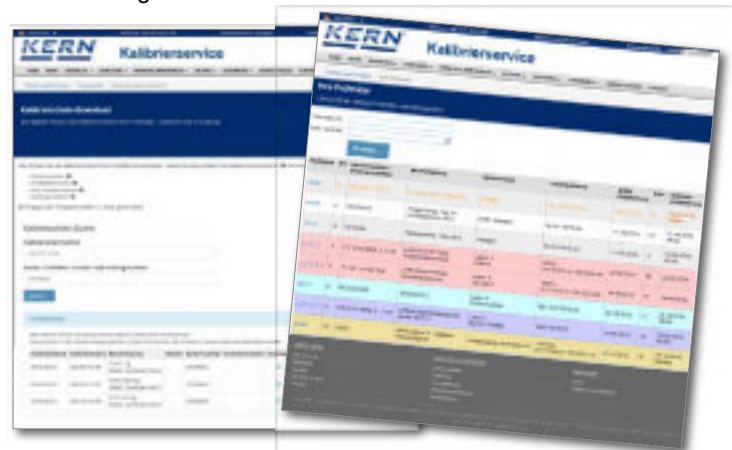

DAkKs Calibration of balances

Any balance will only give correct results if it is checked regularly, i.e. calibrated correctly and adjusted when required. A balance is only a reliable measuring and checking tool if it is calibrated and this calibration is documented. The issued DAkKs calibration certificates are proof of the metrological traceability to national and international standards, as required by the DIN EN ISO 9000 and DIN EN ISO/IEC 17025 standards, amongst others. KERN recommends a recalibration period of one year. The standard does not give a defined recalibration period. KERN recommends that, with intensive (daily) use, you to recalibrate your balance every 6 months and at normal (weekly) use, every 12 months.



THE ADVANTAGES OF USING THE KERN ON-SITE CALIBRATION:

- + **Calibration on-site** at your premises in the field of use
- + **No risk of damage** during transportation
- + **Low downtime**
- + **Cross-brand servicing**, basic inspection and adjustment by a specialist
- + You tell us **when you would like us to come**
- + **Device training** for qualified users



a) KERN on-site calibration (we visit you)

In Germany, KERN has a close-knit network of KERN DAkKs calibration laboratory employees, who can carry out on-site calibration of balances up to 50 tonnes.

This on-site testing service is metrologically recommended, as your balance is in its field of use and can be calibrated without any possible transportation problems.

Lower downtime and personal contact with our expert are the major benefits of this service.

Preparatory maintenance work by agreement. Prices for on-site calibration on request.

You tell us when you would like us to come, giving us details of the balances to be tested. Our on-site DAkKs calibration team will then get in touch with you immediately and will discuss the process with you at your premises – it's straight forward and professional.

This KERN calibration service is also independent of the brand.

Please feel free to contact us at Phone +49 7433 9933-400 or E-Mail: testservices-onsite@kern-sohn.com



THE ADVANTAGES OF USING THE KERN IN-HOUSE CALIBRATION:

- + **Short calibration time:** Test time in the laboratory is only four working days
- + **Competence:** Calibration laboratory, which complies with the highest standards in the area of metrology
- + **Independent management** of the recalibration calendar for your individual measuring instrument is possible
- + **Cross-brand service:** Measuring devices from any manufacturer can be calibrated independently
- + **Repair:** Any necessary repairs can be carried out immediately, if you wish

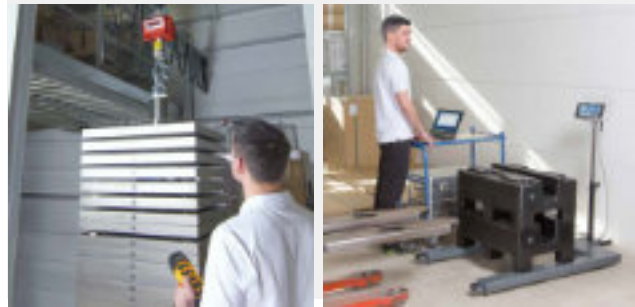

b) Calibration at the KERN factory (you send your balance to us)

Recommended for new devices and for balances which can be affordably transported, as then there is no need for us to travel to carry out the calibration on-site. Repairs can be carried out at the same time, quickly and in full.

The process would be as follows:

- Day 1: Send your balance to the KERN calibration laboratory in Balingen.
- Day 2 to 3: Evaluation and calibration of your balance by our specialists.
- Day 4: After positive validation, your balance is returned.

Please feel free to contact us at Phone +49 7433 9933-400 or E-Mail: recalibration-balances@kern-sohn.com

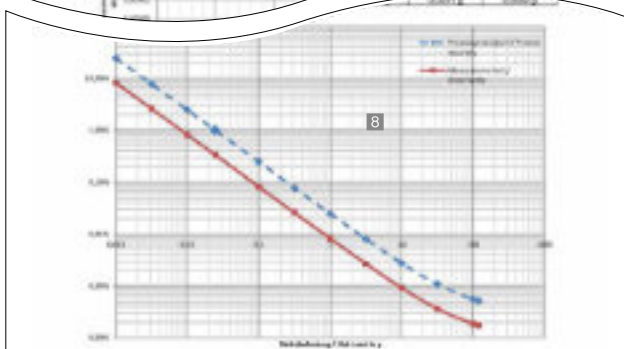
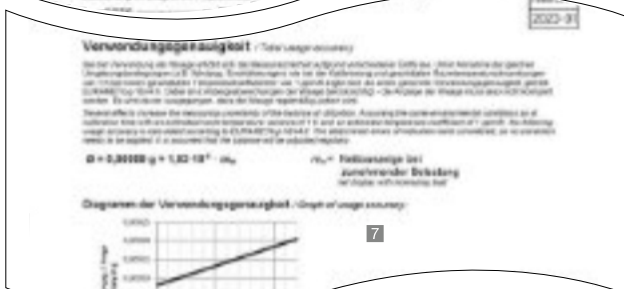
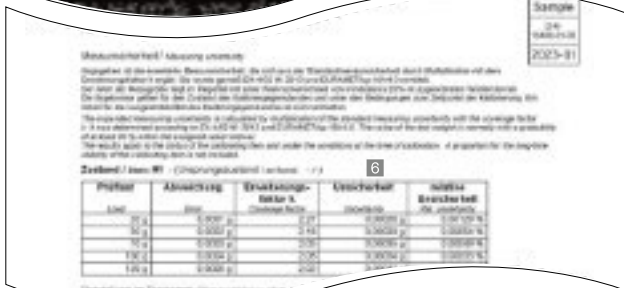

DAkkScalibration certificate for balances (extract)

To get reliable weighing results you need to have calibrated balances. KERN offers you an extensive calibration service for your balances – You have the choice:

Recalibration

- The recalibration schedule depends on the frequency of use, the conditions of use and the safety requirements.
- We would recommend that you recalibrate your balances every 6 months if they are used intensively, and every 12 months with normal use.
- The KERN calibration service is independent of the brand.



Initial calibration and recalibration of balance at the KERNfactory **KERN** **Price** **excl. of VAT** **ex works** **€**

Weighing capacity		
Analytical balances		
[Max] ≤ 5 kg	963-101	182,-
[Max] > 5 kg	963-102	230,-
Precision balances/Industrial scales		
[Max] ≤ 5 kg	963-127	93,-
[Max] > 5 kg – 50 kg	963-128	112,-
[Max] > 50 kg – 350 kg	963-129	139,-
[Max] > 350 kg – 1500 kg	963-130	196,-
[Max] > 1500 kg – 2900 kg ¹⁾	963-131	260,-
[Max] > 2900 kg – 6000 kg ¹⁾	963-132	520,-
[Max] > 6000 kg – 12000 kg ¹⁾	963-133	590,-
Hanging scales/Crane scales		
[Max] ≤ 5 kg	963-127H	93,-
[Max] > 5 kg – 50 kg	963-128H	112,-
[Max] > 50 kg – 350 kg	963-129H	131,-
[Max] > 350 kg – 1500 kg	963-130H	235,-
[Max] > 1500 kg – 2900 kg	963-131H	355,-
[Max] > 2900 kg – 6000 kg	963-132H	590,-
[Max] > 6000 kg – 12000 kg ³⁾	963-133H	830,-
Preparation for recalibration (cleaning, adjustment, function test)	969-003R	24,-
Additional services		
Minimum weight of sample (for details see page 215)	969-103	10,-
Additional measurement points (as part of the) weighing test	963-140	5,20/ measurement point
Additional measurement points (as part of the) repeatability testing	963-140	5,20/ each further measurement point
DAkkS Express service with delivery time 48 hours (only on initial purchase, details see p. 210)	962-116	52,-/ scale
Express shipping: Express supplement for guaranteed delivery on the next working day (if ready for shipment before 12:00 noon)	962-115 <small>(other countries on request)</small>	21,-/ parcel

¹⁾ Floor scales & axle load scales only (Price per weighing panel). Please ask for further details.
²⁾ On request
³⁾ Processing time 4 working days
⁴⁾ Processing time 15 working days

- | | | |
|------------------------------|--|---|
| 1 Official document | 4 Identification/Applicant | 7 Application accuracy, see page 223 |
| 2 Item to be calibrated | 5 Metrological component | 8 Minimum weight of sample (additional price) |
| 3 Traceability, see page 225 | 6 Uncertainty of measurement, see page 225 | |

Minimum weight of sample (in use)

What is the lightest item you can weigh on your balance, while still achieving accurate and reliable weighing results? What exactly is the limit?

The KERN minimum sample weight protocol accounts for the established minimum sample weight of your balance and its location of installation and use with the relative measuring uncertainty. With various safety coefficients and required weighing accuracy (process accuracy), depending on standard or quality-related requirements on the balance being used.

Adjustment at the location of installation

Why?

Adjustment at the location of installation is necessary, as the measuring results of balances depend on the local gravitational force (gravitational acceleration) and therefore depend on the location of use. KERN can carry this out just before shipping at the factor, individually to suit the location of installation.

What are the advantages of carrying out adjustment at the location of installation?

- The balance gives reliable measurement results at the location of installation.
- No time-consuming on-site adjustment necessary.
- You do not need a Service Engineer or any additional weights.
- The balance is ready for immediate use.

Certificate of conformity

With a certificate of conformity you get a statement about whether the balance meets your defined requirements.

In conjunction with a DAkkS calibration certificate it serves as documented proof that the balance fulfils the required process demands. When doing this the process owner for the balance can select from different temperature specifications – depending on its individual requirements:

The higher the selected safety coefficient, the higher the safety when using the balance in a particular process. Typical perturbations when using the balance e.g. small fluctuations in temperature are taken into account. In easily predictable conditions in a professional environment of use, KERN recommends a safety coefficient of 3. For critical processes, a correspondingly higher factor should be selected. The minimum sample weight protocol contains a diagram as well as a table, from which you can ascertain the minimum sample weight for your balance, depending on the process.

Pricing table for adjustment at the location of installation

Weighing capacity	KERN	Price excl. of VAT ex works €
[Max] ≤ 5 kg	961-247	39,-
[Max] > 5 – 50 kg	961-248	48,-
[Max] > 50 – 350 kg	961-249	56,-
[Max] > 350 – 1500 kg	961-250	90,-
[Max] > 1500 – 2900 kg	961-251	119,-
[Max] > 2900 – 6000 kg	961-252	240,-
[Max] > 6000 – 12000 kg	961-253	270,-

For adjustment to the location of installation you need the value for gravitational acceleration at the location of installation, which KERN can calculate using the point of use. The procedure is suitable for balances with a resolution of <math><60,000\text{ d}</math>. For higher resolutions we recommend a balance with an internal adjusting weight or adjustment with a calibrated adjusting weight at the location of installation.

Conformity evaluation on the basis of the:	KERN	Price excl. of VAT ex works €
Usage accuracy*	relative	969-511
	absolute	969-512
Calibration results*	relative	969-513
	absolute	969-514
Measurements as manufacturer or customer specification	Foreign device	969-515
	Customer specifications	969-516
	KERN devices	969-517

relative = %/ absolute = g

*as attachment to the DAkkS calibration certificate (Details see www.kern-lab.com)

Example for absolute customer tolerance (absolute) (Item no. 969-511):

No.	Tare	Load	Display	Deviation	Uncertainty	Customer tolerance	Conformity ¹⁾
1	0 g	500 g	500,00 g	0,00 g	± 0,013 g	± 0,05 g	
2	0 g	1000 g	1000,00 g	0,00 g	± 0,015 g	± 0,05 g	
3	0 g	1500 g	1500,01 g	0,01 g	± 0,017 g	± 0,05 g	
4	0 g	2000 g	2000,01 g	0,01 g	± 0,020 g	± 0,10 g	
5	0 g	3000 g	3000,02 g	0,02 g	± 0,022 g	± 0,10 g	

1) Evaluation criteria: $[[\text{Deviation}]] + [\text{extended measuring uncertainty}] \leq [\text{tolerance}]$

Documented quality of your balances in the log book

Consistently high product quality requires the use of measuring and test equipment that provides comprehensible, consistent and reproducible results. Hence, quality management systems require that measuring and test equipment produces a detailed traceable description and documentation of calibration results and conformity statements. Work not documented is work not done.

Equipment qualification is documentary evidence that a equipment is suitable for the intended purpose and is working faultlessly. A balance log book is used to record all activities and results required for the qualification and monitoring of balances during routine operation. This includes the installation and commissioning of the balances, routine tests, maintenance as well as the recording of special events (failures, repairs, change of location).

The structure of the balance log book is based on the qualification process of the balance. The requirements for the qualification system such as DIN EN ISO 9001, DIN EN ISO/IEC 17025, GLP/GMP, VDA must be taken into account. The log book supports the user in his/her daily work with the balance and is meant to serve as necessary evidence during inspections and audits. The responsibility for maintaining the log book and its appropriate use is to be borne by the user.

Our proposal: Count on our support!

KERN offers this qualification concept throughout. Our validation services are carried out on the spot by technicians of our calibration laboratory and comprise among other things: installation, measurement test inclusive DAkkS calibration certificate as well as records in your qualification log book.

We give you advice already when selecting a new device, for example KERNADB/ADJ, ALS/ALJ, ABS/ABJ, ACJ, ABT, ABP, PLS/PLJ, PNS/PNJ, EG-N, PBS/PBJ, PES/PEJ, about the options of device qualification, as required and will be happy to set up an appointment for qualification at the place of installation. We offer individual calibration and maintenance agreements for the periodically required requalification.

Further information can be found at www.kern-lab.com



Important elements of equipment qualification:



Design qualification (DQ)

With the design qualification, all requirements on which you as a user depend are defined. The purchase decision is made on the basis of the design specifications and the available devices. Careful selection in the DQ can prevent subsequent deficiencies.



Installation qualification (IQ)

All steps to be taken for the installation and commissioning of the equipment are described in detail in the installation qualification. These include among others:

- checking for completeness of delivery and assurance that the delivered equipment meets the required specifications
- a description of the ambient conditions at the place of installation
- proper installation and assurance that the equipment is ready for operation after installation
- documentation of equipment configuration and equipment settings
- Recording and installation of connected peripherals units



Function qualification (OQ)

The operational qualification describes the metrological test performed for the balance at the place of installation. In the course of this all parameters that define the efficiency of a measurement will be checked. Functional qualification is carried out with the help of a standard operating procedure (SOP) and recorded in a calibration certificate. The OQ must be carried out by trained staff with the help of qualified aids (such as certified weights that are traceable to an approved standard). Briefing / training of users must be assured and recorded in the OQ.



Performance qualification (PQ)

The PQ represents documented evidence that the balance or weighing system functions in the selected application as intended. This will be assured by a qualification test of the equipment under real conditions with respect to its surroundings and the problem definition (such as traceable data transmission). If the balance or weighing system is "merely" to be used for weighing it will not be necessary to carry out a PQ as the ability to function has already been proven during the metrological test (OQ).



Maintenance qualification (MQ)

The periodical maintenance, cleaning work and complete metrological test of the balance/weighing system is documented in the MQ by a trained authorised engineer. The results are documented on a DAkkS calibration certificate. Maintenance is carried out with the help of a maintenance schedule.

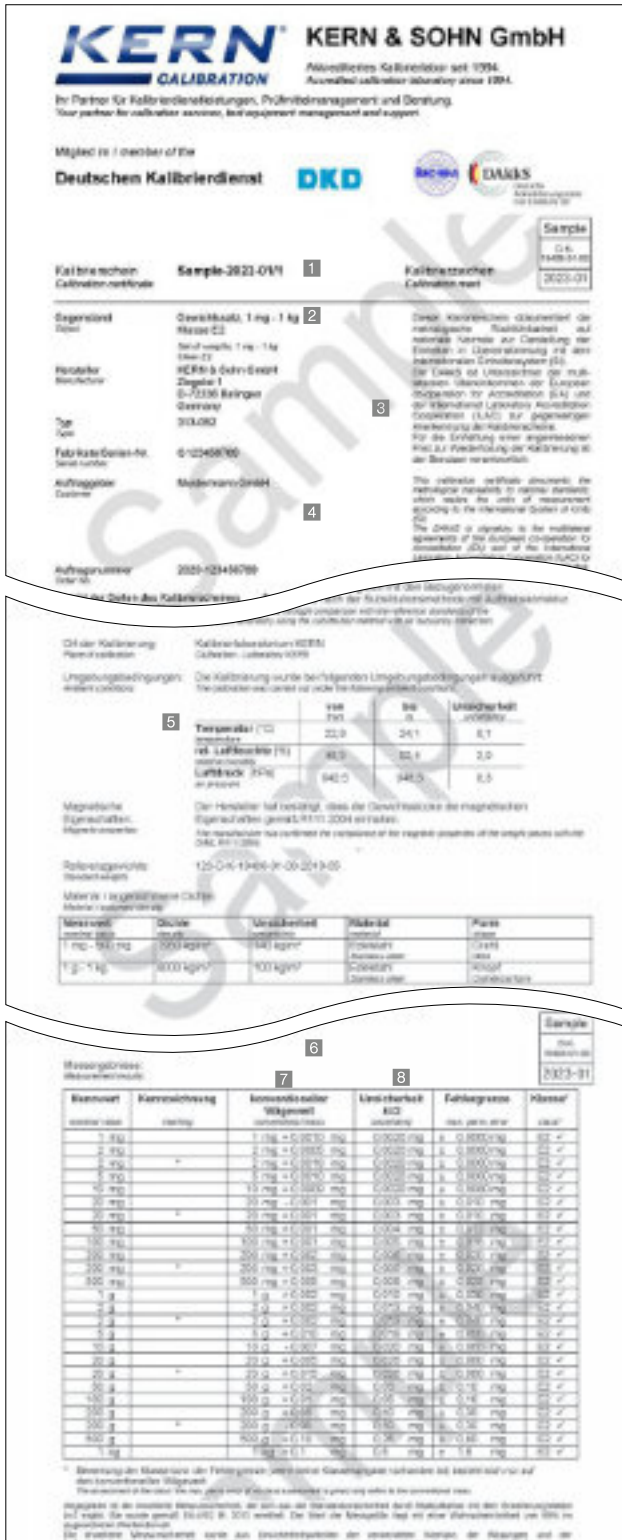

DAkKScalibration certificate for test weights (extract).
For more details on our calibration service and other useful information, please see the internet at www.kern-lab.com

- 1 Official document
- 2 Item to be calibrated
- 3 Traceability, see page 225
- 4 Identification/Applicant
- 5 Environmental conditions
- 6 Metrological component
- 7 Conventional mass
- 8 Uncertainty of measurement, see page 225

Traceable KERNtest weights –

Calibration of test weights

Calibrated measuring equipment requires calibrated checking equipment. For balances, these are calibrated test weights, also called “standard weights”.

KERNwill calibrate your test weights

- In all classes with permissible error limits E1–M3 according to OIML R111:2004 (for tolerance tables, see page 180), in sizes 1 mg to 2500 kg.
- With free nominal value
- Newton (N)
- Independent of design (special designs)

The advantages of using the KERNin-house calibration

You send your test weights to us.

- Excellent price performance ratio
- The quickest processing time
 - DAkKStandard service: 4 working days
 - DAkKexpress service: 48 hrs (new weights)
- The most modern calibration methods with robot controlled comparators allow the most accurate calibration results and fastest throughput time
- KERNDAkKScalibration certificates are internationally recognised
- A calibration service which is independent of the brand
- KERNalso reconditions existing customer weights (e.g. cleaning or readjustment)
- On request, we can also provide a pick-up and collection service with our parcel service

The advantages of using the KERNon-site calibration

We visit you.

We would be pleased to visit you within Germany and carry out the calibration of your reference standards to OIML classes M1–M3, 10 kg–2500 kg with permissible error limits, using our mobile MACOS system. Minimized downtime of your checking equipment and direct contact with our expert are the major benefits of this service. Price on request.

Recalibration

- The recalibration schedule depends on the frequency of use, the conditions of use and the safety requirements
- In terms of standardisation, no particular recalibration interval is specified
- We would recommend that you recalibrate your test weights every six months if they are used intensively, and every 12 months with normal use
- We would be pleased to monitor your recalibration schedule

Recalibration price of test weights (DAkkS calibration)

Class acc.	→ E1 with volume determination	E1 without volume determination	E2	F1/F2 * F2 only	M1/M2/M3					
Nominal value ↓	KERN	Price € excl. of VAT ex works	KERN	Price € excl. of VAT ex works	KERN	Price € excl. of VAT ex works	KERN	Price € excl. of VAT ex works	KERN	Price € excl. of VAT ex works
1 mg	–	–	962-251R	72,-	962-351R	32,-	962-451R	21,-	962-651R	17,-
2 mg	–	–	962-252R	72,-	962-352R	32,-	962-452R	21,-	962-652R	17,-
5 mg	–	–	962-253R	72,-	962-353R	32,-	962-453R	21,-	962-653R	17,-
10 mg	–	–	962-254R	72,-	962-354R	32,-	962-454R	21,-	962-654R	17,-
20 mg	–	–	962-255R	72,-	962-355R	32,-	962-455R	21,-	962-655R	17,-
50 mg	–	–	962-256R	72,-	962-356R	32,-	962-456R	21,-	962-656R	17,-
100 mg	–	–	962-257R	72,-	962-357R	32,-	962-457R	21,-	962-657R	17,-
200 mg	–	–	962-258R	72,-	962-358R	32,-	962-458R	21,-	962-658R	17,-
500 mg	–	–	962-259R	72,-	962-359R	32,-	962-459R	21,-	962-659R	17,-
1 g	963-231	235,-	962-231R	72,-	962-331R	32,-	962-431R	21,-	962-631R	17,-
2 g	963-232	235,-	962-232R	72,-	962-332R	32,-	962-432R	21,-	962-632R	17,-
5 g	963-233	235,-	962-233R	72,-	962-333R	32,-	962-433R	21,-	962-633R	17,-
10 g	963-234	235,-	962-234R	72,-	962-334R	32,-	962-434R	21,-	962-634R	17,-
20 g	963-235	235,-	962-235R	72,-	962-335R	32,-	962-435R	21,-	962-635R	17,-
50 g	963-236	235,-	962-236R	72,-	962-336R	32,-	962-436R	21,-	962-636R	17,-
100 g	963-237	235,-	962-237R	72,-	962-337R	40,-	962-437R	23,-	962-637R	19,-
200 g	963-238	235,-	962-238R	72,-	962-338R	40,-	962-438R	23,-	962-638R	19,-
500 g	963-239	235,-	962-239R	72,-	962-339R	40,-	962-439R	23,-	962-639R	19,-
1 kg	963-241	235,-	962-241R	72,-	962-341R	40,-	962-441R	23,-	962-641R	19,-
2 kg	963-242	520,-	962-242R	89,-	962-342R	49,-	962-442R	29,-	962-642R	20,-
5 kg	963-243	520,-	962-243R	89,-	962-343R	49,-	962-443R	29,-	962-643R	20,-
10 kg	963-244	520,-	962-244R	89,-	962-344R	49,-	962-444R	29,-	962-644R	20,-
20 kg	963-245	1280,-	962-245R	720,-	962-345R	64,-	962-445R	33,-	962-645R	25,-
50 kg	963-246	1500,-	962-246R	800,-	962-346R	74,-	962-446R	45,-	962-646R	27,-
100 kg	–	–	–	–	–	–	962-591R*	134,-	962-691R	72,-
200 kg	–	–	–	–	–	–	962-592R*	134,-	962-692R	72,-
500 kg	–	–	–	–	–	–	962-593R*	134,-	962-693R	72,-
1000 kg	–	–	–	–	–	–	–	–	962-694R	158,-
2000 kg	–	–	–	–	–	–	–	–	962-695R	290,-
1 mg–500 mg	–	–	962-250R	465,-	962-350R	220,-	962-450R	116,-	962-650R	72,-
1 mg–50 g	963-201	1330,-	962-201R	770,-	962-301R	360,-	962-401R	193,-	962-601R	123,-
1 mg–100 g	963-202	1450,-	962-202R	790,-	962-302R	395,-	962-402R	205,-	962-602R	129,-
1 mg–200 g	963-203	1670,-	962-203R	870,-	962-303R	455,-	962-403R	230,-	962-603R	145,-
1 mg–500 g	963-204	1770,-	962-204R	910,-	962-304R	485,-	962-404R	240,-	962-604R	151,-
1 mg–1 kg	963-205	1890,-	962-205R	980,-	962-305R	520,-	962-405R	250,-	962-605R	159,-
1 mg–2 kg	963-206	2460,-	962-206R	1040,-	962-306R	570,-	962-406R	290,-	962-606R	175,-
1 mg–5 kg	963-207	2750,-	962-207R	1080,-	962-307R	610,-	962-407R	305,-	962-607R	185,-
1 mg–10 kg	963-208	3130,-	962-208R	1120,-	962-308R	650,-	962-408R	330,-	962-608R	193,-
1 g–50 g	963-215	960,-	962-215R	340,-	962-315R	149,-	962-415R	78,-	962-615R	48,-
1 g–100 g	963-216	1050,-	962-216R	370,-	962-316R	178,-	962-416R	89,-	962-616R	57,-
1 g–200 g	963-217	1280,-	962-217R	445,-	962-317R	235,-	962-417R	113,-	962-617R	70,-
1 g–500 g	963-218	1390,-	962-218R	490,-	962-318R	270,-	962-418R	126,-	962-618R	79,-
1 g–1 kg	963-219	1520,-	962-219R	520,-	962-319R	300,-	962-419R	138,-	962-619R	85,-
1 g–2 kg	963-220	2130,-	962-220R	600,-	962-320R	370,-	962-420R	174,-	962-620R	103,-
1 g–5 kg	963-221	2500,-	962-221R	620,-	962-321R	415,-	962-421R	192,-	962-621R	111,-
1 g–10 kg	963-222	2910,-	962-222R	670,-	962-322R	450,-	962-422R	210,-	962-622R	120,-

Additional costs for preparation, overhaul and adjustment before the calibration	KERN	Price excl. of VAT ex works €
Preparation of weights (e.g. cleaning, etc.)		
Single weight	969-001R	5,-
Weight set	969-002R	20,-
Subsequent services are carried out after confirmation		
Continued overhaul of weights (e.g. wet-cleaning, markings, repair, special packaging, adjustment E1 (DAkkS only), E2 ...)	969-005R	T & M basis
Adjustment, per weight only available for weights with adjustment chamber (F1–M3)	969-010R	15,-
Second calibration after adjustment or substitution, per weight		
Class E1	969-210R	63,-
Class E1 incl. volume determination	969-211R	230,-
Class E2	969-310R	30,-
Class F1/F2	969-410R	20,-
Class M1–M3	969-610R	16,-
Testing of magnetic properties according to OIML R111:2004, per weight	961-115(R)	15,-
Calibration of NON-OIML test weights, additional price per weight	–	8,-

KERN DAkkS Express Service

DAkkS standard service Class E2–M3	4 working days
DAkkS standard service Class E1, 1 mg–500 mg, and recalibration 1 g–10 kg with a known volume	10 working days
Class E1, ≥ 1 g, incl. volume determination (new weights)	15 working days

 **DAkkS Express service in 48 hours** except for class E1

- Urgent order is received at KERN by 12:00 noon at the latest
- Ready for shipping at KERN within two working days, at 12:00 noon
- Return by standard parcel service or express shipping (Costs and processing time on request)
- Additional cost for DAkkS Express Service, for each KERN test weight KERN 962-115 € 21,-
- For Express shipping, see page 214

Verification prices for test weights and (crane) scales

Class acc. OIMLR111:2004	→ E2 with verification certificate		F1 with verification certificate		M1 with verification certificate	
	Nominal value ↓	KERN	Price excl. of VAT ex works €	KERN	Price excl. of VAT ex works €	KERN
1 mg	952-351	51,-	952-451	44,-	952-651	30,-
2 mg	952-352	51,-	952-452	44,-	952-652	30,-
5 mg	952-353	51,-	952-453	44,-	952-653	30,-
10 mg	952-354	51,-	952-454	44,-	952-654	30,-
20 mg	952-355	51,-	952-455	44,-	952-655	30,-
50 mg	952-356	51,-	952-456	44,-	952-656	30,-
100 mg	952-357	51,-	952-457	44,-	952-657	30,-
200 mg	952-358	51,-	952-458	44,-	952-658	30,-
500 mg	952-359	51,-	952-459	44,-	952-659	30,-
1 g	952-331	51,-	952-431	44,-	952-631	30,-
2 g	952-332	51,-	952-432	44,-	952-632	30,-
5 g	952-333	51,-	952-433	44,-	952-633	30,-
10 g	952-334	51,-	952-434	44,-	952-634	30,-
20 g	952-335	51,-	952-435	44,-	952-635	30,-
50 g	952-336	51,-	952-436	44,-	952-636	30,-
100 g	952-337	57,-	952-437	44,-	952-637	30,-
200 g	952-338	57,-	952-438	46,-	952-638	30,-
500 g	952-339	57,-	952-439	46,-	952-639	30,-
1 kg	952-341	57,-	952-441	46,-	952-641	30,-
2 kg	952-342	65,-	952-442	51,-	952-642	32,-
5 kg	952-343	65,-	952-443	51,-	952-643	32,-
10 kg	952-344	65,-	952-444	51,-	952-644	40,-
20 kg	952-345	75,-	952-445	53,-	952-645	46,-
50 kg	-	-	952-446	64,-	952-646	48,-
1 mg-500 mg	952-350	255,-	952-450	134,-	952-650	84,-
1 mg-50 g	952-301	420,-	952-401	220,-	952-601	140,-
1 mg-100 g	952-302	455,-	952-402	240,-	952-602	149,-
1 mg-200 g	952-303	510,-	952-403	265,-	952-603	166,-
1 mg-500 g	952-304	550,-	952-404	275,-	952-604	174,-
1 mg-1 kg	952-305	570,-	952-405	290,-	952-605	183,-
1 mg-2 kg	952-306	660,-	952-406	330,-	952-606	200,-
1 mg-5 kg	952-307	710,-	952-407	355,-	952-607	215,-
1 mg-10 kg	952-308	750,-	952-408	380,-	952-608	220,-
1 g-50 g	952-315	168,-	952-415	97,-	952-615	64,-
1 g-100 g	952-316	200,-	952-416	103,-	952-616	68,-
1 g-200 g	952-317	260,-	952-417	131,-	952-617	81,-
1 g-500 g	952-318	300,-	952-418	145,-	952-618	90,-
1 g-1 kg	952-319	325,-	952-419	159,-	952-619	99,-
1 g-2 kg	952-320	405,-	952-420	200,-	952-620	118,-
1 g-5 kg	952-321	450,-	952-421	220,-	952-621	129,-
1 g-10 kg	952-322	495,-	952-422	245,-	952-622	138,-

KERN verification delivery time

Standard verification service Class E2-M1 6 working days

Additional costs KERN Price excl. of VAT ex works €
for preparation, overhaul and adjustment before the verification

Preparation of weights (e.g. cleaning, etc.)

Single weight 969-008R 5,-

Weight set 969-009R 19,-

Subsequent services are carried out after confirmation

Continued overhaul of weights (e.g. wet-cleaning, markings, repair, special packaging, adjustment E2 ...) 969-005R T & M basis

Adjustment, per weight only available for weights with adjustment chamber (F1/F2-M1) 969-010R 15,-

Verification after adjustment or substitution, per weight

Class E2 969-310R 30,-

Class F1/F2 969-410R 20,-

Class M1 969-610R 16,-

Verification prices for balances

Accuracy class I (precision balances) ¹⁾

[Max] ≤ 5 kg ¹⁾

Reverification KERN Price excl. of VAT ex works €

950-101R 225,-

[Max] > 5 kg ¹⁾

950-102R 290,-

Accuracy class II (precision balances) ¹⁾

[Max] ≤ 5 kg ¹⁾

950-116R 114,-

[Max] > 5 kg - 50 kg ¹⁾

950-117R 139,-

[Max] > 50 kg - 350 kg ¹⁾

950-118R 215,-

Accuracy class III-IV ¹⁾

Bench scales and industrial scales (excl. crane scales)

[Max] ≤ 5 kg ¹⁾

950-127R 109,-

[Max] > 5 kg - 50 kg ¹⁾

950-128R 109,-

[Max] > 50 kg - 350 kg ¹⁾

950-129R 175,-

[Max] > 350 kg - 1500 kg ¹⁾

950-130R 255,-

[Max] > 1500 kg - 2900 kg ¹⁾

950-131R 355,-

[Max] > 2900 kg - 6000 kg ¹⁾

950-132R 550,-

Crane scales

[Max] > 50 kg - 350 kg ¹⁾

950-129HR 190,-

[Max] > 350 kg - 1500 kg ¹⁾

950-130HR 315,-

[Max] > 1500 kg - 2900 kg ¹⁾

950-131HR 455,-

[Max] > 2900 kg - 6000 kg ¹⁾

950-132HR 690,-

[Max] > 6000 kg - 12000 kg ¹⁾

950-133HR 1100,-

¹⁾ Processing time 4 working days, ²⁾ Processing time 15 working days, ¹⁾²⁾ Preparation of reverification of balances, 969-006R, € 24,-

The force gauge

Accredited calibration with DAkkS calibration certificate for force gauges

The KERN calibration laboratory is at your side when you need to calibrate according to DAkkS.

From the transducer to the full measuring chain, we are happy to take care of traceable calibration of your test equipment for you. Our accreditation includes the calibration of tensile and pressure force up to 5 kN according to the standards DIN EN ISO 376 and DKD-R3-3, each with the Newton (N) display unit for a complete measuring chain (situation A) or voltage ratio/transmission coefficient (mV/V, situation B).

Below you will find a comparison of which standard meets which criteria:

Comparison of DIN EN ISO 376 and DKD-R3-3

	ISO 376	DKD-R 3-3
Standardization	ISO standard (internationally standardized)	Standard of the DKD (Germany)
Measuring equipment	Force transducers and complete measuring chains	Force transducers and complete measuring chains
Area of application	Specifically force gauges for the testing of testing equipment	General force gauges
Number of power stages	8	5
Classification/Assessment	Classification in classes 00; 0,5; 1 and 2	None in standard
Test sequences	Fixed procedure	Sequences A, B, C, D possible Standard is sequence A B, C and D are reduced sequences, relevant previous knowledge is necessary
Summary	Higher-quality calibration, as 8 force levels are calibrated	High-quality calibration, reduced sequences with less effort possible

We can offer you a calibration solution for the following situations:

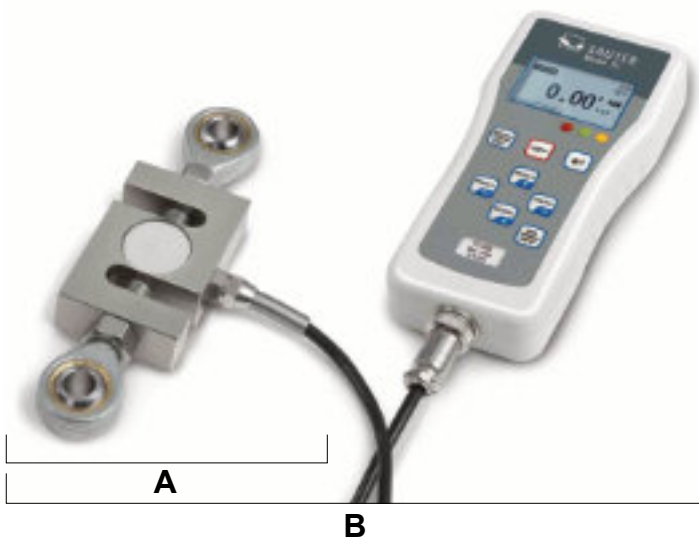

Situation A:

Separate force transducer, display unit mV/V

Situation B:

Complete force gauge (N), consisting of transducer, amplifier and display, display unit N

► See also tables, right side

You can find further information on this topic at: www.kern-lab.com

DAkkS Calibration certificate for force-measuring devices (extract).

Prices for DAkKS calibration of force gauges and force transducers

Situation A: Force transducer (voltage ratio, in mV/V)^{*1,2}

ISO 376 (8 stages)			DKD-R3-3 (5 stages, sequence A)		
KERN	Measuring range	Price € ex works excl. of VAT	KERN	Measuring range	Price € ex works excl. of VAT
Tensile force:					
963-161IV (R)	≤ 500 N	225,-	963-161V (R)	≤ 500 N	210,-
963-162IV (R)	≤ 2 kN	270,-	963-162V (R)	≤ 2 kN	250,-
963-163IV (R)	≤ 5 kN	350,-	963-163V (R)	≤ 5 kN	325,-
Compression force:					
963-261IV (R)	≤ 500 N	225,-	963-261V (R)	≤ 500 N	210,-
963-262IV (R)	≤ 2 kN	270,-	963-262V (R)	≤ 2 kN	250,-
963-263IV (R)	≤ 5 kN	350,-	963-263V (R)	≤ 5 kN	325,-
Tensile and Compression force:					
963-361IV (R)	≤ 500 N	375,-	963-361V (R)	≤ 500 N	350,-
963-362IV (R)	≤ 2 kN	450,-	963-362V (R)	≤ 2 kN	420,-
963-363IV (R)	≤ 5 kN	600,-	963-363V (R)	≤ 5 kN	550,-

Situation B: Complete force gauge (in N)^{*2}

ISO 376 (8 stages)			DKD-R3-3 (5 stages, sequence A)		
KERN	Measuring range	Price € ex works excl. of VAT	KERN	Measuring range	Price € ex works excl. of VAT
Tensile force:					
963-161I (R)	≤ 500 N	186,-	963-161 (R)	≤ 500 N	168,-
963-162I (R)	≤ 2 kN	225,-	963-162 (R)	≤ 2 kN	205,-
963-163I (R)	≤ 5 kN	310,-	963-163 (R)	≤ 5 kN	285,-
Compression force:					
963-261I (R)	≤ 500 N	186,-	963-261 (R)	≤ 500 N	168,-
963-262I (R)	≤ 2 kN	225,-	963-262 (R)	≤ 2 kN	205,-
963-263I (R)	≤ 5 kN	310,-	963-263 (R)	≤ 5 kN	285,-
Tensile and Compression force:					
963-361I (R)	≤ 500 N	335,-	963-361 (R)	≤ 500 N	305,-
963-362I (R)	≤ 2 kN	415,-	963-362 (R)	≤ 2 kN	375,-
963-363I (R)	≤ 5 kN	560,-	963-363 (R)	≤ 5 kN	500,-

Factory calibration for force

Situation A: Force transducer (voltage ratio, in mV/V)^{*1,2}

Situation B: Complete force gauge (in N)^{*2}

Situation A: Force transducer (voltage ratio, in mV/V) ^{*1,2}			Situation B: Complete force gauge (in N) ^{*2}		
KERN	Measuring range	Price € ex works excl. of VAT	KERN	Measuring range	Price € ex works excl. of VAT
Tensile force:					
961-161V (R)	≤ 500 N	210,-	961-161 (R)	≤ 500 N	168,-
961-162V (R)	≤ 2 kN	250,-	961-162 (R)	≤ 2 kN	205,-
961-163V (R)	≤ 5 kN	325,-	961-163 (R)	≤ 5 kN	285,-
961-164V (R)	≤ 20 kN	415,-	961-164 (R)	≤ 20 kN	370,-
961-165V (R)	≤ 50 kN	415,-	961-165 (R)	≤ 50 kN	370,-
961-166V (R)	≤ 250 kN	445,-	961-166 (R)	≤ 120 kN	410,-
Compression force:					
961-261V (R)	≤ 500 N	210,-	961-261 (R)	≤ 500 N	168,-
961-262V (R)	≤ 2 kN	250,-	961-262 (R)	≤ 2 kN	205,-
961-263V (R)	≤ 5 kN	325,-	961-263 (R)	≤ 5 kN	285,-
961-264V (R)	≤ 20 kN	415,-	961-264 (R)	≤ 20 kN	370,-
961-265V (R)	≤ 50 kN	415,-	961-265 (R)	≤ 50 kN	370,-
961-266V (R)	≤ 250 kN	445,-	961-266 (R)	≤ 120 kN	410,-
Tensile and Compression force:					
961-361V (R)	≤ 500 N	350,-	961-361 (R)	≤ 500 N	305,-
961-362V (R)	≤ 2 kN	420,-	961-362 (R)	≤ 2 kN	375,-
961-363V (R)	≤ 5 kN	550,-	961-363 (R)	≤ 5 kN	500,-
961-364V (R)	≤ 20 kN	590,-	961-364 (R)	≤ 20 kN	550,-
961-365V (R)	≤ 50 kN	590,-	961-365 (R)	≤ 50 kN	550,-
961-366V (R)	≤ 250 kN	650,-	961-366 (R)	≤ 120 kN	600,-

(R): Recalibration

For each force gauge without interface or from other manufacturers we charge a surcharge of € 10,- for the additional effort.

*1 Compatibility with our amplifiers required

*2 Installation in our measuring equipment required

Factory calibration certificates

As DAkkS calibration certificates cannot be offered for all measuring devices or measurement sizes, or where it is not customary, we then offer factory calibration certificates. These calibration certificates meet international standards and are particularly suitable as proof of exacting calibration in the monitoring of your checking equipment, for example:

- Mechanical balances (spring balances, etc.)
- Force-measuring devices up to 250 kN (see also page 221)
- Measuring devices for layer thickness 0 µm – 2000 µm
- Hardness testing devices in accordance with Leeb tests
- Ultrasonic material thickness testing device 25 mm - 300 mm

We carry out calibrations independent of brand. In order to avoid any unnecessary delays when processing your order, please send us the technical documents and necessary accessories with the checking device. Calibration time 4 working days.

For up-to-date information on test services for further measuring variables please see p. 221 or visit our website www.kern-lab.com

KERN	Measuring device	Measuring range	Price excl. of VAT ex works €
Factory calibration			
961-110	Coating thickness	≤ 2000 µm F or N	150,-
961-112	Coating thickness	≤ 2000 µm FN	210,-
961-113	Wall thickness (ultra sound)	≤ 300 mm (in stainless steel)	150,-
961-114	Wall thickness (Test blocks)	≤ 300 mm	187,-
961-170	Hardness comparison plate (Shore)	For sets up to 7 plates	119,-
961-131	Hardness tester (Leeb)	400–800 HLD	150,-
961-132	Hardness comparison plate (Leeb)	Hardness comparison plate (for Leeb durometer)	150,-
961-270	Hardness (UCI)	200 - 800 HV	325,-
961-150	Length	≤ 300 mm	150,-
961-190	Light	≤ 200000 lx	205,-
961-100	Mechanical balances/spring balances	≤ 5 kg	89,-
961-101	Mechanical balances/spring balances	> 5–50 kg	110,-
961-102	Mechanical balances/spring balances	> 50–350 kg	131,-
961-103	Mechanical balances/spring balances	> 350–1500 kg	205,-
961-102K	Digital dynamometer KERN MAP	≤ 130 kg	150,-
961-120 (R)	Torque wrench test devices	1 Nm - 200 Nm	210,-
964-305	Temperature calibration for moisture analyzer*		174,-
Additional services			
962-116	Express service with 48 hour delivery		52,-/ instrument

(R): Recalibration

For each force gauge without interface or from other manufacturers we charge a surcharge of € 10,- for the additional effort.

*Calibration available for the following models:

DAB 100-3, DAB 200-2, DBS-60-3, DLB 160-3A, MLS 150-2A, MLS 65-3A, MLB 50-3N, MLB 50-3C, MLB 50-3, DLT 100-3N, MLS 50-3D, MLS 50-3C



A

Accuracy classes for test weights

E, F, M ▶ **Error limit classes**

Adjusting of measurement equipment

Precise setting of a measurement value via a professional intervention in the measurement system.

Adjusting the weighing range of a balance



Either with the external test weight via the **adjusting program CAL**, or with the **internal automatic adjustment** resp. **adjusting switch**. It is necessary with variations in temperature, a change of environmental conditions, change of location, etc.

Recommended as a daily check routine.

Alibi memory

For weighings where verification is mandatory, and which are to be analysed and processed by a PC (e.g. printing out a packing list using a PC instead of a printer connected directly to the balance) electronic archiving is required by the metrological authorities by a verifiable data memory which cannot be manipulated. Alibi memories from KERN fulfil this requirement. They are for paperless archiving of weighing results. For KERN products the alibi memory is fitted inside the balance, right between where the weight is determined and the output to the PC.

All data transferred to the PC is stored with date, time and all important weights for at least three months. These stored data strings can be displayed on the balance at any time. The data in the alibi memory can be deleted, but not changed.

Application accuracy

Allowance for measuring uncertainty during practical use of a balance. Is given in the appendix to the DKD calibration certificate.

ATEX

Derived from **AT**mosphère **EX**plosibles. (explosive atmosphere). A synonym for EU guidelines, which controls the quality and use of equipment in hazardous industrial environments, where there is explosion danger, e.g. by handling of flammable substances, which are present in high concentrations in the form of gas, mist, vapour or dust. Therefore see also directives 2014/34/EU as well as 1999/92/EU.

B

Balances which are verified/not approved for verification

Metrologically almost identical. For verified balances certain details are regulated by law, e.g. software changes and additional markings.

C

CAL

Adjusting the balance is triggered with an external test weight by using the CAL key on the key pad or on the touch display of the display device or the CAL menu option. This will guarantee the consistent high accuracy of the balance.

Calibration of measurement equipment

Determination of the precision of a measurement value without intervention in the measurement system. Example: to check a balance you load a ▶ **test weight** upon it. The term "Calibrating" was formerly also used for ▶ **Adjusting**.

Calibration Certificate DKD/DAkkS



See product group 18 "Calibration service"

Calibration or verification



DAkkS-Calibration is possible for every balance in perfect condition. DAkkS calibration (DKD) is a private service monitored by the state for ensuring high quality requirements according to ISO 9000ff and others, e.g. in production or research. **Verifying (conformity assessment)** is only possible for type-approved balances marked with the green **M** ▶ **Verification**

Commercial error limit

Permitted tolerance (plus and minus) of measuring devices where verification is mandatory when used within their verification validity period. This tolerance is double the permissible error limit, in so far as this is not specified otherwise in the Weights and Measures Act).

Conformity assessment

Procedure for confirming warranted characteristics in accordance with recognised rules. For balances this relates to verification.

Conformity declaration from the manufacturer

The manufacturer declares that the product fulfils the applicable EU directives. With electronic balances this is always in conjunction with the CE mark.

Control of measuring equipment in the QM system in conjunction with quality standards

An organisation certified to a quality standard such as DIN EN ISO 9001 ff. e.g. a production plant is obliged to adhere to a defined quality standard within the framework of its quality management system. To do this, it is imperative to have a measurement equipment which is working accurately. Chapter 7.1.5 "Resources for monitoring and measuring" of DIN EN ISO 9001:2015-11 states that measuring equipment must be calibrated at defined intervals and before use. The measurement devices and measurement standards needed to do this must:

- be traced back to international or national standards.

(▶ **Traceability to the National Standard**)

- their uncertainty of measurement must be known- they must be marked with a clear identification

- the test must be documented

The ▶ **DAkkS Calibration (DKD)** fulfils all these requirements.

Conventional mass of weights

The problem is the air movement, which makes the weight appear lighter. In order to avoid this "distortion" in daily use, all weights are adjusted to the unit specifications given in R111, e.g. it is accepted that: material density of the weights is 8000 kg/m³, air density is 1.2 kg/m³ and measuring temperature is 20°C.

Counting resolution

The counting resolution is calculated in points from the ratio of the weighing range [Max] divided by the smallest part weight. It is a statement of counting accuracy.

D

DAkkS = German accreditation authority

▶ **Calibration Certificate DKD/DAkkS**

See product group 18 "Calibration service"

Data interface



To connect the balance to a printer, PC, network or a second balance. Typical interfaces are, for example, RS-232, RS-485, USB, Bluetooth, LAN, Digital I/O, DUAL, LAN etc. The interface parameters can be set using the balance. The interfaces available are stated in the model description.

Density determination

One of the main areas of application for laboratory balances is determining densities, e.g. determining the specific weight of liquids and solids. To do this you will need a highly accurate precision or analytical balance and a density set. It is particularly convenient if the balance can calculate and display the density right away.

It has become apparent that by means of weighing when in the process of determining the density of liquids and solids according to the buoyancy method particularly accurate results can be obtained (Archimedes' principle).

- Density determination of liquids: By means of measuring the buoyancy with a glass plummet with known volume immersed in the liquid to be measured
- Density determination of solid bodies:

$$\rho = \frac{A}{A-B} \cdot \rho_0$$

ρ = Density of sample

A = Weight of sample in air

B = Weight of sample in auxiliary liquid

ρ_0 = Density of the auxiliary liquid

Glossary

Applications:

- Pre-packaged goods control, whenever a product is sold according to its volume [cm³]. This volume is calculated with weight [g] : density [g/cm³].
- Materials analysis

DMS = Strain gauge



An electrical resistor strip that is glued to an elastic deforming body made of aluminium. As the strain gauge is mechanically deformed its resistance value changes, allowing the measured value to be calculated.

Draught shield

Required for balances with ▶ **Readout** $d \leq 1$ mg, to avoid disturbing air movements.

Dual-range balance

As the load increases, the balance switches automatically to the next largest range, for both, weighing range [Max] as well as readout [d].

E

Error limit classes for test weights according to EU directive OIML R111

For further details, see product group 17 "Test weights"

F

FACTORY

These options can only be carried out at KERN factory.

FORCE= Electromagnetic force compensation



A counterforce is created by means of a coil in a permanent magnet. This counterforce is the same as the load of the weight being measured on the scale and therefore equalising. The measured value is calculated via the change in the coil current.

G

GLP= Good Laboratory Practice

▶ **ISO/ GLP**

Gravitational acceleration

▶ **Gravitational force**

Gravitational force

very important influence for precise electronic balances. Due to the varying influence balances have to be ▶ **adjusted at the location of use.**

H

HACCP

= **Hazard Analysis and Critical Control Points (HACCP)** The HACCP concept is a preventative system, which is designed to guarantee the safety of foodstuffs. EC regulation 852/2004 mandates the use of the HACCP concept for all companies which are involved in production, processing and sales of foodstuffs.

ISO 9000ff/DIN EN ISO 9000ff

Quality Management System in the form of a DIN Norm for quality assurance in a factory.

ISO calibration/ISO certificate = factory calibration certificate

Testing measurement devices for accuracy in accordance with a procedure which is recognised, but not accredited.

ISO/GLP record keeping



Quality Assurance Systems demands record keeping of weighing results and correct adjusting of the balance, giving details of date, time and balance identification. The easiest way to obtain this documentation is by means of a connected printer.

J

Junction Box

For connection and simple corner adjustment of several load cells.

K

KCP

KCP is a universal communication protocol between laboratory balances, industrial scales or other measuring instruments and digital devices, such as a computer, server or process management system. Due to the universal protocol structure, one measuring instrument can be replaced by another without adapting the communication interface.

L

Linearity/Precision

Greatest deviation of the weight displayed of a balance with regard to the value of the respective test weight in terms of plus and minus across the whole weighing range.

M

Minimum load [Min]

Lower limit of the verifiable weighing range. Is marked on the verification mark. The function of the balance is also given below the minimum load.

Minimum sample weight

Indicates the smallest weight which can be determined, depending on the process accuracy required.

Multi-division balance/ Multi-range balance

On multi-division balances, the weighing range is subdivided several times, each with a different readability. The readability [d] changes automatically with increasing and decreasing load. Multi-range balances have several weighing ranges with different maximum loads and different numerical increments. Switching takes effect automatically when the load increases; switching back to the lower weighing range only takes effect when the scale has been completely unloaded.

N

Newton

Newton (N) is the unit for physical force values. A Newton is the force required to accelerate a 1 kg mass at rest to a speed of 1 m/s within one second.

Notified body

Neutral and independent, predominantly government bodies, which are formally appointed by the EC. They are engaged in the field of verification for conformity evaluations (initial verification) and type-approval test within the scope of type approvals.

O

Optimisation of reference weight (when piece counting)

See product group 9 "Counting balances/ Counting systems".

P

Percentage determination



Example: Reference weight prior to drying: 50g = balance display 100%. After drying 40g = balance display 80% absolute (dry mass) or 20% relative (humidity).

Permissible ambient temperature

Measuring errors are possible if you use the balances outside the permitted specified ambient temperature range. With verified balances this is stated on the identification plate.

PLU (Price Look Up)

This refers to a data memory in price-computing retail scales for the base price of sales items.

Pre-packaging legislation (FPVO)

Ensures that pre-packed goods are filled correctly, for example, in food industry. The Weights and Measures Act governs the permissible weight and volume tolerances.

PRE-TARE

Entering and saving a tare weight (e.g. container weight) through weighing or manual entry using the balance keypad before the actual weighing process. When you subsequently place the tare container on the balance, the balance will show zero immediately – saves time. Particularly useful e.g. for checking fill levels

Proof of compatibility

This documents the verification compatibility for combinations of weighing modules such as display devices, load cells and connecting elements.

R**Readout [d]**

Smallest readable weight increment on a digital display.

Recalibration

Periodic checking of the precision of measurement equipment/checking equipment (e.g. balances/weights) to control accuracy, **►Control of measurement equipment**

Reference weight (when piece counting)

See product group 9 "Counting balances/Counting systems".

Reproducibility (standard deviation)

Sequenced measure of conformity in repeated weighing (e.g. balances) subject to the same conditions. Mostly 1 [d] or less. Quality feature.

Resolution of a balance

The resolution is calculated from the weighing range [Max] divided by the readout [d], e.g. [Max] 420 g : [d] 0.001 g = 420,000 points. The resolution is a quality feature – the higher, the better.

S**SC-TECH= Single-Cell-Technology**

►FORCE. The load cell consists of a single aluminium block, which gives a very high measurement quality.

Semi-micro balance

Analytical balance with a readout [d] = 0,01 mg

Smallest part weight when counting

The smallest piece weight, which a balance can accept for piece counting. For the relevant model, enter "g/piece" in the product data table.

T**T-FORK= Tuning fork principle**

A resonating body (like a tuning fork) is electromagnetically excited, causing it to oscillate. The measured value is calculated via the change in frequency corresponding to the load of the weight being measured on the scale.

Taring, automatic

►PRE-TARE

Taring, subtractive

The available weighing range of a balance is reduced by the value of the tare load. Example: weighing range of a balance Max 6000g, Tare (= container) 470g, available weighing range 5530g.

Test weight, external (previously calibration weight)

For adjusting or checking the balance accuracy **►Adjusting the weighing range.** The external test weight can be DAkkS calibrated at any time, even afterwards, see product group 18 "Calibration Service".

Test weight, internal

Like test weight external, but installed in the balance and powered.

Totalising

Various individual weighings are added automatically to aggregate, e.g. all individual weighings of a batch.

Traceability to the National Standard

A pre-requisite for every perfect measurement is the validated comprehensive proof that the measuring equipment can be traced back to the international or national standards. In Germany the statutory binding standards are available from the PTB.

Type approval for balances

Strict process to test whether a balance fulfils the verification requirements. A balance can only be verified, if it has got a type approval from a **►notified body.**

U**Uncertainty of measurement of a balance (= standard deviation)**

Determined for each balance according to a precisely given test method and documented in the **►Calibration certificate.** It depends on various factors, both, internal and external. Uncertainty of measurement increases by a rising charge of the balance, see product group 18 "Calibration Service"

V**Verification**

Verification, in accordance with the new terminology "Conformity assessment". Only balances with **►EC type approval** can be evaluated for conformity. These balances have an identification plate with the metrology marking **M.** The state requires assessment for conformity and this assessment serves as consumer protection. According to EU directive 2014/31/EEC balances must be officially assessed for conformity (calibrated) if they are used as follows:

- in commercial trade when the price of a commodity is determined by weighing.
- in the manufacture of pharmaceuticals in pharmacies and analysis in pharmaceutical and medical laboratories.
- for official purposes.
- in the production of prepackaging.
- in medical applications.

Every balance is tested by KERN and marked with a conformity mark. Its accuracy within the framework of permissible tolerances is thereby confirmed. EU verification applies to all member states of the EU.

Verification classes of balances

Class I – Analytical balance (precision balance), Class II – precision balance, Class III – industrial scale (commercial scale).

Verification of a balance with adjusting program CAEXT

The adjusting program is sealed with an official mark after the verification. Thus the verification is only valid for the specific location of use.

►Gravitational force

To be able to correctly adjust the balance to your location of use, it is necessary to advise the location of use and postcode. See individual model details for the information as to whether verification can be carried out in the factory or at the location of use.

Verification of a balance with automatic internal adjusting CALINT

The above restrictions in respect of the location of use do not apply, because the automatic internal adjusting works also after verification, therefore it is not sealed. In this case, verification does not depend on the location.

Verification validity for balances

Generally 2 years for all verification classes, for control balances generally 1 year, after expiry the balance has to be re-verified.

Verification value [e]

Measure of the verification tolerance, depending on balance, mostly between 1 [d] and 10 [d] **►Readout**

W**Weighing range [Max]**

is the working range of the balance. The balance can be loaded up to the specified upper limit.